

# AP Dynamometer Specifications

**DILLON**



## Pound Capacities

5" (125 mm) Dial Size		10" (250 mm) Dial Size		Ultimate Safety Factor	
	<u>Part Number</u>	<u>Cap x Division Size</u>	<u>Part Number</u>	<u>Cap x Division Size</u>	
LOW	30006-0019	500 x 5	N/A		5:1
	30006-0027	1,000 x 10	30007-0026	1,000 x 5	5:1
	30006-0035	2,000 x 20	30007-0034	2,000 x 10	5:1
	30006-0043	4,000 x 25	N/A		5:1
	30006-0050	5,000 x 50	30007-0059	5,000 x 20	5:1
	30006-0076	8,000 x 50	N/A		
	30006-0084	10,000 x 100	30007-0083	10,000 x 50	5:1
MED	30006-0092	15,000 x 100	N/A		
	30006-0100	20,000 x 200	30007-0109	20,000 x 100	5:1
HIGH	N/A		30784-0017	30,000 x 200	5:1
	N/A		30784-0033	50,000 x 200*	3:1

\*Not CE approved.

ASME b30.26 compliant on 20,000 lb (10,000 kg) and below.

## Kilogram Capacities

5" (125 mm) Dial Size		10" (250 mm) Dial Size		Ultimate Safety Factor	
	<u>Part Number</u>	<u>Cap x Division Size</u>	<u>Part Number</u>	<u>Cap x Division Size</u>	
LOW	30006-0134	500 x 5	N/A		
	30006-0159	1000 x 10	30007-0158	1000 x 5	5:1
	30006-0126	2000 x 20	30007-0125	2000 x 10	5:1
	30006-0167	4000 x 25	N/A		5:1
	N/A		30007-0174	5000 x 20	5:1
MED	30006-0118	10000 x 100	30007-0117	10000 x 50	5:1
HIGH	N/A		30784-0058	20000 x 100	4:1

# Model AP Dynamometer Dimensions

Dimensions in inches (mm)  
 Drawing scales differ between capacities  
 Dimensions subject to manufacturer /supplier tolerances and  
 are subject to change without notice.

Low & Medium Capacities  
 500-20,000 lb / 200-10,000 kg

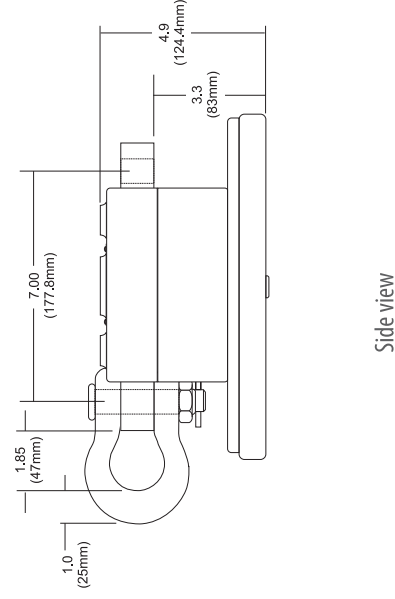
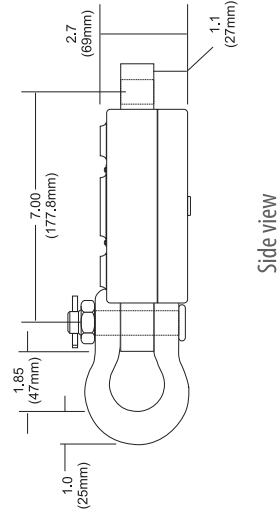
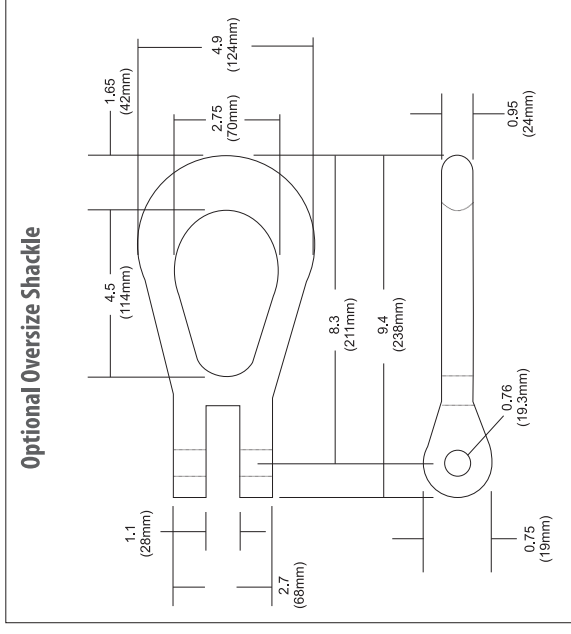
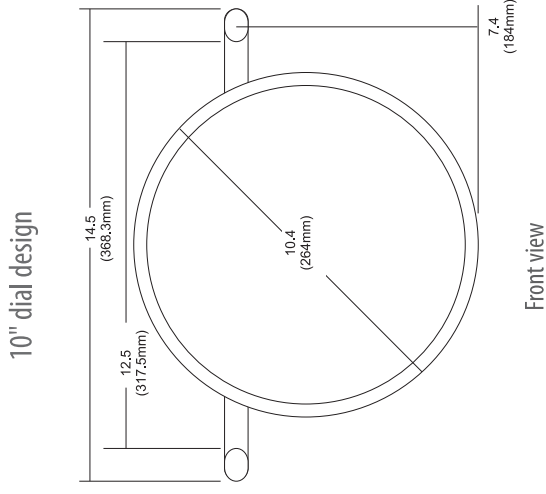
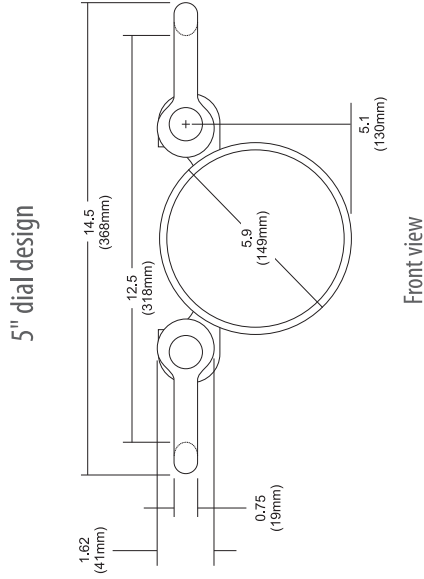

Standard Shackle

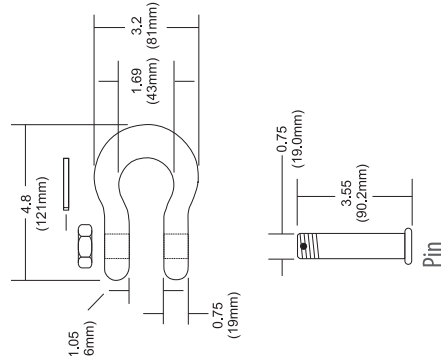

# High Capacities 30,000-50,000 lb / 15,000-20,000 kg

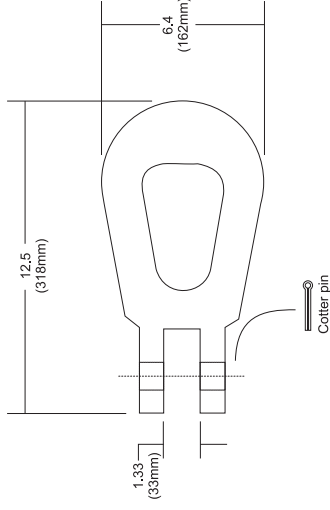
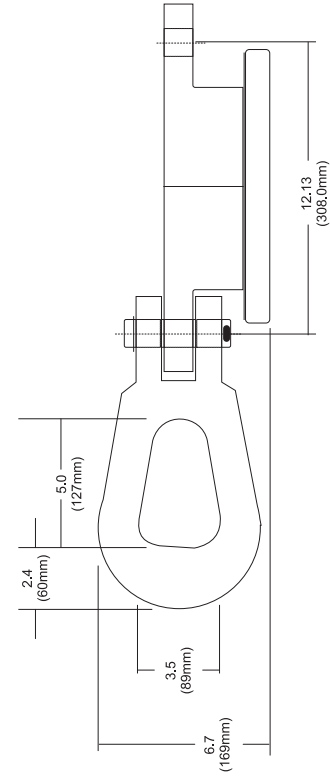
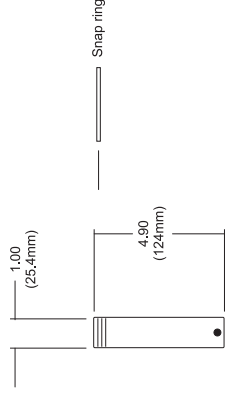
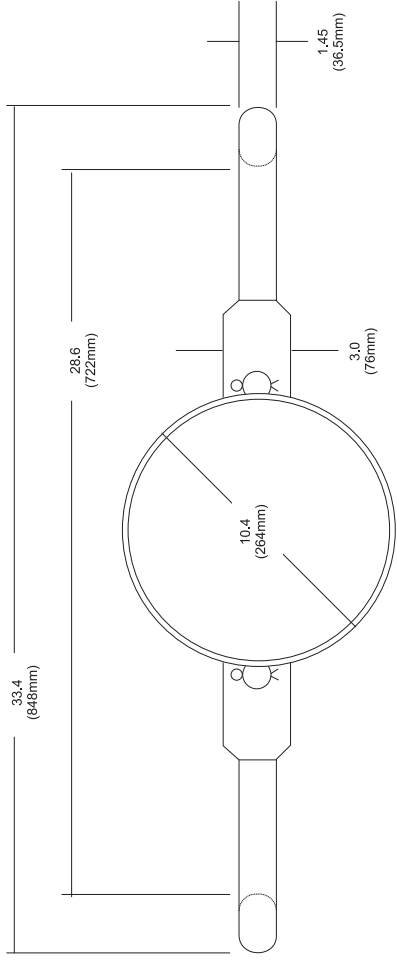

# Model AP Mechanical Dynamometer

**Accuracy:**  $\pm 0.5\%$  of capacity

**Temperature Range:** -50° to 140° F (-45° to 60° C)

**Ultimate Safety Factor:**

See table on cover for minimum USF

**Construction:**

*Pressure bar—*

High-grade E4340 alloy steel or 7075-T651 aluminum

*Shackles—*

A4140 forged steel (machined from E4340 steel)

*Shackle pins—*

Machined from E4340 steel or 300 m steel

**Case Housing:**

5" models are equipped with high strength composite plastic case.

10" models use cast aluminum enclosure.

**Corrosion Protection:** Pressure bar protected with durable powder coat paint. Shackles and pins are electroless nickel plated. All integral machining and fasteners are produced from noncorrosive materials or have suitable plating.

**Zero Control:** Zero up to 20% of capacity. Zeroed load must be considered as part of ultimate load.

**Calibration:** Traceable to NIST.

**Documentation:** Includes users guide and signed calibration certificate.

**Carry Case/Crate:**

Low/Med capacity 5" dial – includes plastic carry case

Low/Med capacity 10" dial – optional steel carry case

All high capacity – includes reinforced plywood crate

**Periodic Proof Loads:** Controlled 150% proof loads permitted annually.

**Approval:** CE on all capacities excluding 50,000 lb  
ASME b30.26 compliant on 20,000 lb (10,000 kg) and below

**Warranty:** 2 years parts and labor

**Shipping and packing** (approximate weights):

**5" Low and Med Capacities**

Net weight	9 lb
Shipping weight	15 lb
Shipping box	16" x 11" x 7"

**10" Low and Med Capacities**

Net weight	10 lb
Shipping weight	16 lb
Shipping weight <i>(with optional steel case)</i>	26 lb
Shipping box	14" x 14" x 8"

**30,000 – 50,000 lb (20,000 kg) High Capacity**

Net weight	64 lb
Shipping weight	98 lb
Shipping crate	37.5" x 13" x 10.5"



**DILLON**

Force Measurement Equipment

[www.dynameasure.com](http://www.dynameasure.com)